

Early Liquid Fuels and the Controversial Octane Number Tests

E. L. Marshall
Newcomen Society

After briefly describing early motor and aviation fuels and the different approaches to fuel quality in the USA and Great Britain, the paper covers the formation of the Cooperative Fuels Research (CFR) Committee and the establishment of a laboratory 'Octane Number' test in 1930 which ranked fuels in the order of their anti-knock performance in a laboratory engine, but failed to predict vehicle anti-knock performance on the road. Subsequent road/laboratory correlations carried out at Uniontown, Pennsylvania, resulted in a second, modified, octane number test which improved the prediction of some vehicle/fuel relationships. However, the author argues that the restricted choice of paraffinic hydrocarbons for laboratory reference fuels is a contributory factor in for the failure of the laboratory Octane Number tests to predict road performance accurately. A USA/GB divergence in the design and use of aircraft engines led to the need for a further two anti-knock performance tests for aviation fuel.

KEYWORDS: Combustion, Gasoline, Engine, Octane Number

Petroleum Before the Internal Combustion Engine

Prior to the drilling of the first successful oil well, by Colonel E.L. Drake, at Titusville, Pennsylvania, in August 1859 a small number of refineries had been engaged in the production of burning oil for use in oil lamps; this was a type of kerosene, starting from raw material known as 'coal oil'.

The name 'Kerosene' was registered in the United States in 1853 by Dr Abraham Gesner, a Canadian physician and geologist, who in 1846 demonstrated the production of burning oil which he made from Trinidad bitumen. In Britain he had already been beaten to the Patent Office by James Young, a Scottish manufacturing chemist, who in 1850 patented the production of burning oil from bituminous coal and called it 'Paraffin'. The highly flammable hydrocarbon fractions obtained as a by-product of this refining were of little or no use at that time and much was burned to waste.¹ Amongst those in Britain working along these lines was Dr Eugene Carless who established a small refinery on the edge of Hackney Marshes in East London, to produce lamp oil that was much cheaper than the vegetable oils previously available.²

American petroleum, in the form of a rough kerosene, started to arrive in Europe in about 1866 and there was a strong incentive for the Americans to

incorporate into the kerosene the maximum possible amount of the unwanted lighter fractions. This caused numerous accidents because the imported oil was far from safe for use as a lamp oil, and resulted in Frederick Abel designing flash-point apparatus to ensure that the kerosene sold to the public was free from the lighter fractions. These lighter fractions were removed by distillation, and pot stills such as those installed by Carless at Hackney Wick were ideal for this purpose. However refiners were still left with the problem of what to do with the lighter fractions and whilst some were 'flared off' a variety of other uses were found, particularly in the cleaning industry. The rapid development of the gas industry at this time also provided an outlet because the coal gas was at first somewhat deficient in illuminating power and it was soon discovered that the light petroleum vapour gave a considerable improvement in luminosity when blended with the coal gas.

Early Liquid Fuels for the Internal Combustion Engine

From the 1830s Britain led the field with the development of steam powered coaches and carriages until the 1865 'Red Flag' Act made it compulsory for a mechanically propelled vehicle not to exceed a speed of four miles per hour on the road and to have an advance guard bearing a red flag. This drove all but steam-rollers off the roads so Britain had to watch her French and German neighbours go on to develop steam, electric and finally liquid fuelled internal combustion engine vehicles. The passing of the 'Locomotives on Highways' Act in 1896 repealing much of the 'Red Flag' Act released a stream of activity as Britain struggled to catch up with her neighbours.

In 1890 a young engineer, Frederick Simms, arrived in England with the intention of introducing motor launches on the country's waterways. Simms, whilst British by decent, had been born in Hamburg and he had developed an intimate personal friendship with Gottlieb Daimler who at that time was interested in internal combustion engines for use in motor launches. It was these German engines that Simms fitted to his early launches built in England. Whilst various types of 'motor spirit' were in both development and use in Germany, no suitable spirits were available, in sufficient quantity, in England where cars with internal combustion engines were few in number. This situation led Simms to consult with Carless, Capel & Leonard Ltd who furnished him with supplies of a 0.68 SG 'Launch Spirit'. By 1893 Simms had converted his business into a limited liability company called Daimler Motor Syndicate Ltd. and he was now regularly taking much larger quantities of 'Launch Spirit'. Simms and William Leonard, who was now running the refining company, decided that they should give the 'Launch Spirit' a more distinctive name and, at Simms suggestion, they decided to call it 'Petrol'. At that time the sales of 'Petrol' were very small but once motorcars started to become more popular Leonard realized how important the sales of

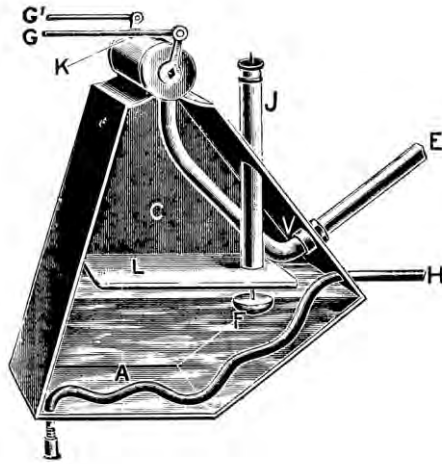

- A. Twisted tube for the passage of a small portion of hot exhaust gas from H to heat the petrol.
- C. Carburettor, in which the mixture of air and vaporised spirit to feed the explosions is produced.
- E. Pipe conveying gas from G to motor.
- F. Float.
- G. Gas lever, controlling quantity of gas.
- G'. Air lever, controlling quality of gas.
- J. Tube admitting air to carburettor.
- K. Hole admitting air to twin tap.
- L. Metallic plate forming cover above the petroleum spirit in carburettor.
- V. Safety chamber.

Figure 1. De Dion Bouton Surface Carburettor.

‘Petrol’ could become so he tried to register the word as a Trade Mark. Unfortunately the Registrar of Trade Marks would not admit it on the grounds that it was a descriptive word and as the law then stood, although a new word, it could not be registered. However his competitors agreed to call their motor spirits by other names.³

The first motor cars were fitted with surface carburettors where a portion of the incoming air was either passed over the surface of a pool of fuel which had been slightly heated by the engine exhaust, or was ‘bubbled’ through a small tank of fuel, thereby picking up the lighter fractions and mixing with more air before passing into the combustion chamber (Figure 1).

This had the disadvantage of leaving in the pool, or tank, all the heavier fractions, so causing difficulties with subsequent cold starting. The wick carburettor soon replaced the surface carburettor where a portion of the intake air was passed over lamp wicks, the lower ends of which were suspended in fuel (Figure 2). In this way saturated air was taken to a mixing chamber where it was added to pure air to give the correct mixture strength for combustion. All of this

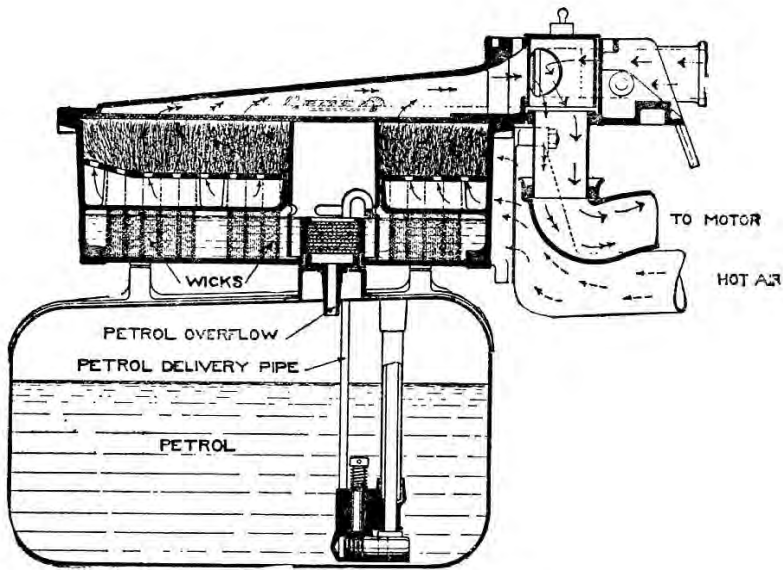

Figure 2. Lanchester Wick Carburettor.

meant that fuel quality was judged by volatility, the more volatile the better, and volatility was expressed in terms of specific gravity, so the lower the gravity the better the fuel. Although the surface and wick carburettors were quickly replaced by the more benign ventury type, the quality of motor fuel was judged mainly by its specific gravity for the next twenty years. The experience was eloquently expressed by Harry Ricardo in a lecture given many years later:

I first drove a car and so came into contact with petrol in 1898. The engine of this car was an ordinary horizontal single cylinder gas engine, with all its working parts open to the winds of heaven and the dusts of the earth below; exposed to everything, in fact, except lubrication. Its supply of gas was drawn from what used to be termed a wick carburettor – an enormous vessel kept about one quarter full of petrol in which were suspended dozens of lengths of lamp wick. Some of the air supply was drawn past these wicks and was saturated with petrol vapour, while the remainder past direct to the inlet valve of the engine – thus a combustible mixture was obtained, but seldom, if ever, did the engine and I agree as to the definition of a combustible mixture, and the engine always got the better of the argument. It was an unfair debate, for the engine always had the last word, spat scornfully, and then sulked. In time, one developed a sort of sixth sense and was able to feed the engine with one hand and steer with the other.⁴

In those early days, fuel suppliers were equipped with hydrometers so that they could check the quality of the spirit. The fuel was obtained by simple distillation and was known as 'straight run spirit' it would probably have a boiling range of about 50 – 120 °C and therefore consisted mainly of paraffinic hydrocarbons.

With carburation improved, manufacturers turned their attention to other aspects of engine performance, including the raising of compression ratio for increased power and efficiency, and they very quickly ran into problems of combustion knock. This knock was first diagnosed as premature ignition of the charge by some surface within the combustion chamber which had become overheated, this was in spite of the fact that improved cooling had no effect and no auto ignition occurred when the spark was switched off. Nor could anyone explain why premature ignition should produce a high-pitched ringing noise.

In 1904 Professor Bertram Hopkinson was conducting some experiments on an engine in his laboratory at Cambridge University, ably assisted by a young student called Harry Ricardo, when he experienced combustion knock. Hopkinson was not convinced by the pre-ignition diagnosis, so the pair went on to devise an experiment in which they deliberately induced pre-ignition in an engine, and found the knock to be quite different from the combustion knock which they had previously heard. This confirmed Hopkinson's belief that the knock in the petrol engine was due to something quite distinct from pre-ignition, which he described as detonation. He came to the conclusion that the knock in the petrol engine was due to the shock of a gaseous wave striking the walls of the cylinder and this he attributed to some peculiarity of the fuel. Unfortunately Hopkinson never published any of this work and the belief that combustion knock was due to pre-ignition remained unchallenged by all except a few of his disciples.⁵

From 1904 to 1907 the annual consumption of motor fuel in Britain rose from 30,000 to 100,000 tons.⁶ Whilst oil was still imported from the USA increasing amounts were now coming from Rumania and, from 1904, Asiatic Petroleum (Shell) was importing oil from the Dutch East Indies. The growth in the gas industry resulted in a growth of associated products, one of which was benzole; this was originally removed from town gas to clean the gas and make it less odorous and smoky, it consisted primarily of benzene, toluene and xylene. About 1910 benzole began to become available in sufficient quantity for use in motor spirit and Ricardo who, as a hobby, had privately continued the investigations which he and Hopkinson had started in Cambridge, discovered that with this fuel detonation disappeared entirely. This caused him to focus on the nature of the fuel as the primary factor in detonation.

The First World War

By 1914 a critical aviation design problem was the provision of adequate cooling of the air-cooled cylinders to ensure detonation-free performance and it was recognized that fuel source and mixture strength had a significant bearing on this

aspect of performance. British operators found that the straight run spirit from Rumanian and Dutch East Indian crudes was vastly superior to that obtainable from normal American sources (except California). Although octane number ratings were still more than a decade away, estimated octane numbers would be 45-55 for American fuel and around 70-75 for Rumanian, Dutch East Indian and California gasolines. In Europe, batches of aviation fuel were selected for engine performance on a trial-and-error basis and the only known method of remedying unsatisfactory quality was to add coal tar benzole up to the limit (ca 20%) dictated by the need to avoid solidification in cold weather.⁷

Thus, until well into the First World War, motor spirit for both ground vehicles and aircraft was merely a low gravity, straight run distillate with aircraft stocks being selected from crude sources known to provide superior engine performance. By 1917, however, the overall demand for gasoline became so great that it was necessary to augment supplies by increasing the back-end boiling range. America entered the war at this stage and became the main Allied source of gasoline whose typical quality was 60 ON or less; this caused considerable difficulties in European aircraft engines and recourse had often to be made to benzole addition. Later on, American specifications were set up for Domestic Aviation Grade (DAG) and Fighting Grade aviation fuels, the later being somewhat more volatile. However, the normal American criterion of quality was specific gravity – a low value being indicative of good volatility – and this made Pennsylvanian gasoline (as low as 40 ON) appear better than Californian fuel (ca. 70 ON).

Post War – the parting of the ways





Britain 1918 - 1930

When hostilities ceased in 1918 developments in fuel quality differed in Britain and America and this divergence was to become greater in the next decade. In Britain the accent was on good anti-knock quality. During the war there had been a huge demand for toluene for nitration to make trinitrotoluene (TNT) an explosive; with the war over the large demand for toluene abated and so motor benzole became available for use as a motor fuel⁸ and in 1919 a group of independent coke and gas producers formed The National Benzole Company to market benzole. Early in 1919 Ricardo completed his E35 variable compression ratio engine and with the assistance of Henry Tizard and David Pye, and the financial and technical backing of the Asiatic Petroleum Company (Shell), he started an investigation into the engine performance of various fuels.

He developed two methods of assessing the relative anti-knock performance. With the first method, using a standard set of conditions the compression ratio was raised until audible detonation was experienced on the sample fuel, this ratio was then recorded as the Highest Useful Compression Ratio (HUCR) for that particular fuel. Ricardo reported that with a little practice they

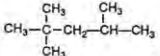
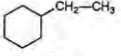
were able to determine the compression ratio at which detonation occurred to within one-twentieth of a ratio and thus to detect very small differences between fuels. For the second method Ricardo devised a Toluene Number scale based on comparing the sample with blends of toluene/low quality gasoline but this was not reliable because the reference toluene and low quality gasoline were not of a consistent anti-knock quality. In 1921 he published the results of his very comprehensive studies of the knock resistance of individual hydrocarbons.⁹ The studies indicated that superior performance was in the order aromatics > naphthenes > paraffins which, in hindsight, was a misleading generalization with regard to the excellent anti-knock performance of isoparaffins (Table 1).¹⁰ However, the work reinforced the British trend to consider good fuel quality in terms of aromatic content. The volatility characteristics of motor fuel were relegated to a secondary consideration.

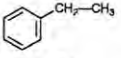
Table 1. Effect of fuel molecular structure on engine octane quality – examples amongst hydrocarbons containing eight carbon atoms.

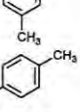
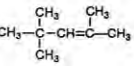
Type	Name	Structure	Octane number (research)	Boiling point °C
Straight-chain paraffin	n-octane: CH ₃ -CH ₂ -CH ₂ -CH ₂ -CH ₂ -CH ₂ -CH ₂ -CH ₃	$\text{CH}_3-\text{CH}_2-\text{CH}_2-\text{CH}_2-\text{CH}_2-\text{CH}_2-\text{CH}_2-\text{CH}_3$	< 0	98
Branched-chain paraffin	2,2,4-trimethyl pentane: (isooctane)		100.0	99
Naphthene	ethylcyclohexane		45.6	130
Naphthene	1,1-dimethylcyclohexane		87.3	119
Aromatic	ethylbenzene		108	136
Aromatic	1,2-dimethylbenzene		113	144
Aromatic	1,3-dimethylbenzene		118	139
Aromatic	1,4-dimethylbenzene		117	138
Olefin (straight-chain paraffin)	1-octene: CH ₂ =CH-CH ₂ -CH ₂ -CH ₂ -CH ₂ -CH ₂ -CH ₃	$\text{CH}_2=\text{CH}-\text{CH}_2-\text{CH}_2-\text{CH}_2-\text{CH}_2-\text{CH}_2-\text{CH}_3$	28.7	122
Olefin (branched-chain paraffin)	2,4,4-trimethyl-2-pentene:		105	102

America 1918 – 1930

In America, with the exception of the work of Kettering and Midgley, the reverse was true with the accent on volatility, and anti-knock performance taking a

backseat. During the war, Kettering and Midgley had worked on the anti-knock properties of aviation gasoline in an attempt to run Liberty engines at higher compression ratios and in connection with this work Midgley developed a benzole/cyclohexane (20/80) fuel which gave an exceptional performance in a high compression engine.¹¹ This first synthetic fuel was not a commercial proposition at that time and the implications of the work were disregarded in America for many years. These investigators also appreciated the high anti-knock quality of Californian fuel, a fact that was not recognized by those US authorities who were responsible for setting fuel specifications.

American vehicle production was rising at an incredible rate. In round figures, from 1918 to 1928 vehicle registrations quadrupled (Table 2).¹²

Table 2. American Motor Vehicle Registrations

<i>Year</i>	<i>Vehicles Registered</i>
1918	6,146,617
1919	7,565,446
1920	9,231,941
1921	10,464,715
1922	12,239,853
1923	15,092,197
1924	17,595,373
1925	19,954,347
1926	22,001,393
1927	23,224,144
1928	24,750,000

Initially, gasoline production was struggling to keep up, many feared fuel shortages and in 1920 Kettering claimed that the USA was producing about 1¾ gallons of fuel per car per day.¹³ To counter these perceived shortages the refining companies increased the back-end boiling range of gasoline and started to employ cracking processes, thereby increasing the yield of gasoline from a given crude oil (Table 3).¹⁴

Table 3. Percentage of Petroleum Products Produced from Crude Oil Run to Refineries.

<i>Product</i>	<i>1916 (%)</i>	<i>1928 (%)</i>
Gasoline	19.8	41.3
Kerosene	14.0	6.6
Gas Oil & Fuel Oil	45.0	46.6
Lubricants	6.0	3.8
Wax, Misc. & Loss	15.2	1.7

The automobile industry reacted to the increase in back-end boiling range with alarm, being very unhappy with the consequent reduction in overall gasoline volatility and suggested imposing a quality standard on the oil suppliers. The oil industry accused the carmakers of not doing enough to improve vehicle economy and this became known within the two industries as 'The Fuel Problem'. Animosity grew between the industries, each accusing the other of not doing anything to resolve matters and relationships deteriorated.

The situation was retrieved when the American Petroleum Institute (API) initiated a conference to address 'The Fuel Problem' and a Cooperative Fuel Research (CFR) Committee was established in 1920 to oversee joint investigative programmes and solutions. Apart from representatives of the two industries the Society of Automotive Engineers (SAE) also played an instrumental role with the American Bureau of Standards being chosen, as an impartial research organization, to carry out many of the studies. Initially all the programmes were related to volatility and fuel consumption, ease of starting, crankcase oil dilution and acceleration.

Aviation Gasoline (1920-1930)

In 1920 US aviation fuel quality was still broadly defined by DAG and Fighting Grade specifications which did not recognize anti-knock quality; supplies were purchased largely on considerations of volatility and costs. Commercial operators were similarly uncritical of quality and so supplies were generally of poor anti-knock rating with benzole being used in limited quantities as a performance improver. The higher quality of Californian supplies was therefore not sufficiently attractive to command the necessary transportation premium. This neglect of anti-knock quality persisted until about 1930 although some intermittent development work was undertaken by both Army and Navy workers.

The Army technical department at McCook Field undertook sporadic investigation of DAG fuel quality which was so bad at times that up to 20 per cent benzole addition was required to suppress knock even in the uncritical Liberty engine. Shortages of benzole meant that aromatic amines were used, however whilst these reduced knock, they produced rubbery engine deposits. Although Army and Bureau of Standards work did show that indigenous fuel supplies varied widely in engine performance, there was no attempt made to raise the quality of service supplies by specifying either an engine performance standard or fuel source. DAG fuel was still purchased against Federal Specification Board requirements and this was probably because the version of the Liberty engine current at that time performed tolerably well on this grade.¹⁵

The US Navy, on the other hand, quickly put control of aviation fuel quality on a much sounder basis by establishing a Naval Bureau of Aeronautics in 1921 to improve engine design and fuel procurement. Due to earlier service use of

air-cooled engines, the Navy encountered knock problems before the Army and was the first service to procure fuel to a specification demanding a comparative knock test. Indeed, with commercial supplies of tetraethyl lead (TEL) becoming freely available in 1926 the Navy adopted the operational use of leaded fuel for supercharged Pratt and Whitney Wasp engines, with the aircraft actually carrying around cans of TEL fluid for addition whilst refueling; this practice did not cease until about 1933.

In 1927 the Army began to encounter serious knocking difficulties with its large air-cooled engines (Wasp, Cyclone and Hornet) so the Chief of the Power Plant Section at McCook Field initiated a systematic investigation of aviation fuel problems. The engine used for these investigations was a small water cooled 'Delco' engine; it so happened that this engine was simultaneously being used for tests to find an alternative to water as an engine coolant and for one series of fuel tests the coolant was changed to ethylene glycol, this resulted in the engine running much hotter than usual. The increased engine temperature changed the relative performance of various fuels; benzole blends were de-rated, in contrast to Californian fuels containing TEL. From this work there evolved the concept of severe/mild engines and sensitive (aromatic)/insensitive (paraffinic) fuels. Full scale studies using various types of engine and supercharging amply demonstrated the value of higher quality fuels and the US Army took the critical policy decision that the requirements of air-cooled engines (severe) dictated the use of insensitive fuels (paraffinic) and that aromatic fuels were relatively ineffective. This was the start of the long-standing American prejudice against aromatic fuels which was reinforced by the US civil aviation preoccupation with cruise (lean mixture) performance. In contrast, British investigations based on liquid-cooled engines, emphasis on maximum power and a tradition of aromatic aviation fuel, were slowly evolving the rich mixture concept of fuel performance.

In Britain the previously mentioned work of Ricardo reinforced the trend to consider good aviation fuel quality in terms of aromatic content. Fuel development work based on Air Ministry requirements, during this period, often involved total aromatic contents of up to 38 per cent volume which was the permitted maximum. Thus towards the end of the decade, British aviation gasoline was either a straight run product from a selected crude or a blend of lower quality gasoline with large proportions of benzole. By 1930 the Air Ministry was calling for a good quality fuel that had to be tested against a Ministry reference fuel in a Ricardo E-35 engine and eventually in an Armstrong Whitworth variable compression ratio engine. The aromatic content of such fuel was indirectly controlled by a specific gravity of 0.70 (max) and a freezing point of -50°C (max).¹⁶

Development of the Octane Number Test as a Method for Rating Fuels for Knock

In April 1926 the CFR Steering Committee asked the Bureau of Standards to make a survey of all the published methods of measuring the anti-detonating quality of motor fuel, and the results were presented the following year.¹⁷ The Bureau reviewed only published data and the conclusions reached were (a) nearly all the methods in use consisted of engine tests or depended on engine tests for their interpretation; (b) knock intensity was measured in various ways and with differing degrees of definiteness; (c) the antiknock value of a fuel was expressed in a variety of terms according to the particular method of test; and (d) the rating of fuels by existing methods was usually not independent of test conditions.

At the February 1928 meeting of the CFR Steering Committee the suggestion was made that something should be done about establishing a universal method of measuring detonation, and a sub-committee was appointed with the instruction to proceed with the development of a method of rating fuels for knock that would “be of universal application and usefulness”.¹⁸

a) The engine

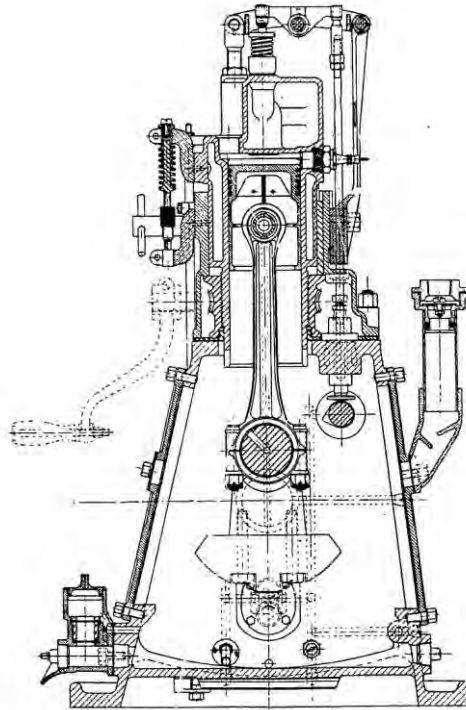

Figure 3. Variable Compression Ratio CFR Engine.¹⁹

By January 1929 the sub-committee reported that their first objective, that of designing and building a suitable engine to serve as the nucleus of a knock testing

outfit, had been accomplished. The engine had been designed such that all the various methods of test in current use could be evaluated using the one engine in either the fixed, or variable, compression ratio layout. The engine was designed by H.L. Horning, a member of the CFR Committee and President of the Waukesha Engine Co and it was built by that Company. During the informal discussion which followed this January 1929 meeting, representatives of a number of laboratories described their methods of knock testing and frankly told of the limitations and difficulties encountered. A difference of opinion developed in a discussion of the relative merits of road tests and laboratory tests, the results of which, it was pointed out, were often not in agreement. Subsequently a small number of these CFR engines were built and distributed to members of the sub-committee who carried out initial evaluation tests. The engine design was then modified to include the necessary changes highlighted by the evaluation tests, and the variable compression ratio version (Figure 3) was chosen as engine to be used in all future CFR knock evaluation testing.

b) Knock Detection

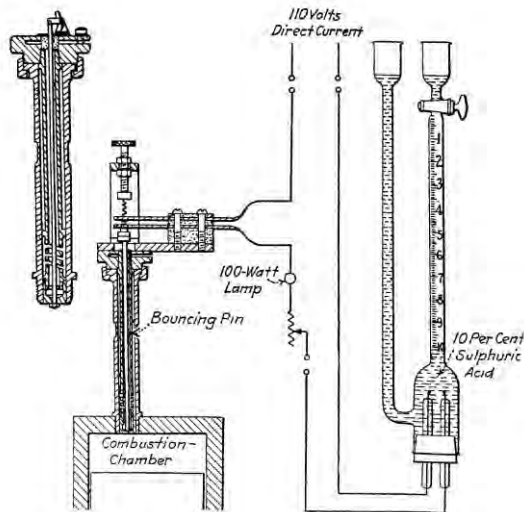

Figure 4. Original Bouncing Pin Knock Detection Equipment.²⁰

The next stage was to establish a reliable means of detecting and measuring the degree of knock. Back in 1922 Midgley and Boyd carried out an investigation into the various methods of detecting knock and concluded that, for a number of reasons, the use of the bouncing pin gave the best results²¹ and it was this system which the CFR Sub-Committee decided to adopt for their method.

As shown in Figure 4, the pin is a steel rod, the lower end of which rests on a diaphragm that is made of 0.015 inch thick alloy steel with a very high elastic limit;

the upper end is made of a non-electrically conductive material. Just above the pin are two leaf springs, the lower one resting lightly on the top of the pin, and each bearing at its inner end tungsten points set at an adjustable gap of 0.007-0.009 inches. The contact points are connected in an electrical circuit which includes a gas evolution burette filled with a solution of 10% Sulphuric Acid in Distilled Water. The bouncing pin element is screwed into the combustion chamber of the engine and, when knock occurs, the pin is thrown upwards closing the electrical circuit; this produces gas in the burette which collects in the graduated arm of the U-tube. The volume of gas collected in a given interval of time depends on the number and intensity of the impulses given to the bouncing pin during that time. Later Ethyl Gasoline Corporation/Weston Electrical Instrument Company developed a knockmeter device for integrating the current flowing in the bouncing pin circuit as a result of knock. The current produced flows through a resistance wire of small diameter located in such a position relative to a thermocouple as to heat it as uniformly as possible. It is the voltage produced in this thermocouple that registers on the scale of the knockmeter (see Figure 5).

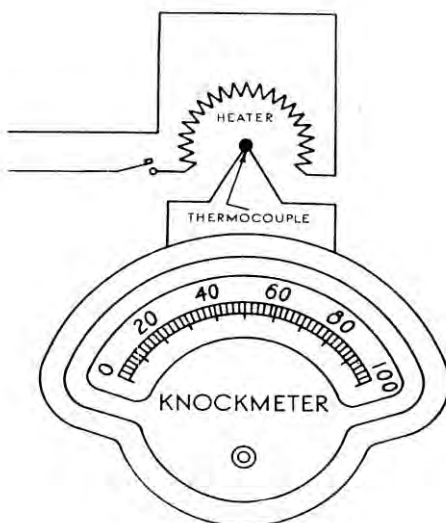

Figure 5. Modified Knockmeter.²²

c) Method of Test

The Sub-Committee considered all the various test procedures which had been listed in the Bureau of Standards survey of methods²³ and eventually settled on the number scale method as used by Ricardo and mentioned earlier. This method compares the knock level of the sample, with the knock level of a mix of two

reference fuels, under identical engine conditions. They did not however, choose the Ricardo reference fuels of, a straight run gasoline and toluene.

d) Reference Fuels

The choice of standard reference fuels was fraught with difficulty. In 1927 Graham Edgar of the Ethyl Corporation published an article in *Industrial and Engineering Chemistry* in which he pointed out the problems of choosing two reference fuels against which gasoline could be rated; he wrote:-

The composition of gasoline is so complex and the knocking characteristics of its different constituents are so varied, that the task of establishing any such material as a reproducible standard seems hopeless. Ideally, the standard mixture should be composed of one or more hydrocarbons, the purity of which can be definitely established by test and thus will be absolutely reproducible.²⁴

He went on to suggest two pure hydrocarbons that he felt were ideally suited as standard reference fuels. As a low reference fuel he suggested pure normal heptane, this material was prepared from Jeffery Pine Oil in a state of absolute purity and it had a tendency to knock which was much more pronounced than that of any automotive fuel that was then in current use. The other pure hydrocarbon was an iso-octane (2,2,4 trimethyl pentane) prepared synthetically from tertiary butyl alcohol. Although it is, like heptane, a paraffinic hydrocarbon, it has a much higher antiknock performance, although not as high as alcohols and aromatics (Figure 6).²⁵

In the discussion following Edgar's presentation of his normal heptane/iso-octane suggestion, to the SAE,²⁶ he was asked by a W.A. Gruse of Pittsburgh University if he had tried a mixture of normal heptane and toluene. Edgar avoided the question and spoke of the use of benzol but Gruse persisted, asking "What was the actual difference in performance of mixtures containing toluene and octane?" to which Edgar replied "I have never compared mixtures of toluene and heptane in our laboratory".

Edgar's reluctance to consider toluene is interesting and can only be put down to the American aversion to aromatics following the US Army experience with aviation gasoline (mentioned previously). Ricardo and others had used toluene successfully and it could be prepared cheaply to a reasonable degree of purity, it had a much higher antiknock performance than iso-octane and gave a second hydrocarbon type to the reference standard. At the 1930 Annual Meeting of the SAE, three senior personnel from the General Motors Research Laboratories presented an excellent review of iso-octane, cyclohexane, benzene, toluene and alcohol as possible high antiknock reference fuels.²⁷ Many people, including the British, felt that it was misleading to rate a full boiling range gasoline, containing a

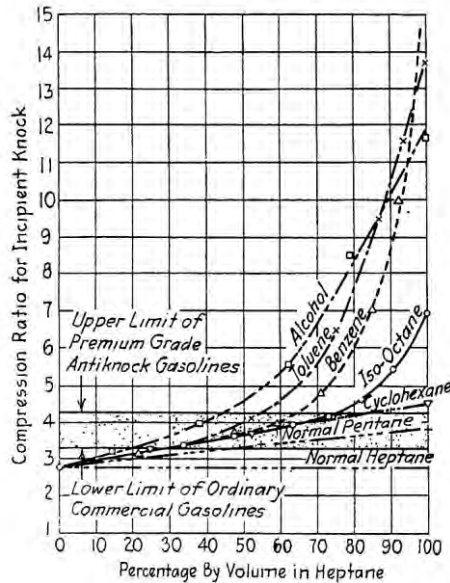

Figure 6. Detonation Characteristics of some Antiknock Standards.

mixture of dozens of different hydrocarbon types, against a reference standard of a single hydrocarbon type.

The Sub-Committee decided to go along with the Edgar recommendation of normal heptane and iso-octane as the reference fuels. This recommendation was to have repercussions for years to come.

e) Octane Number Definition

The Sub-Committee decided that for tests using the above equipment, materials and procedure the result would be expressed as an Octane Number, defined as follows:-

The Octane Number of any gasoline is the percentage of octane by volume in the mixture of octane and heptane that just matches the gasoline anti-knock quality, as determined in the apparatus described and by the procedure specified.

Therefore, by definition, iso-octane has an octane number of 100, and n-heptane one of zero.

At that time the CFR Committee did not envisage a situation where fuels would be required, or manufactured, with an anti-knock performance better than that of iso-octane, so when the need eventually arose a system had to be devised. For fuels with an antiknock performance greater than 100 ON, a known amount of

tetraethyl lead (TEL) is added to the iso-octane reference fuel and the octane level is expressed as say “100 + 0.5”, indicating that the fuel has an anti-knock performance equal to that of iso-octane to which 0.5 ml of TEL/US Gall has been added. Later still a formula was devised to convert these values into ‘pseudo’ octane numbers as displayed in Figure 7.

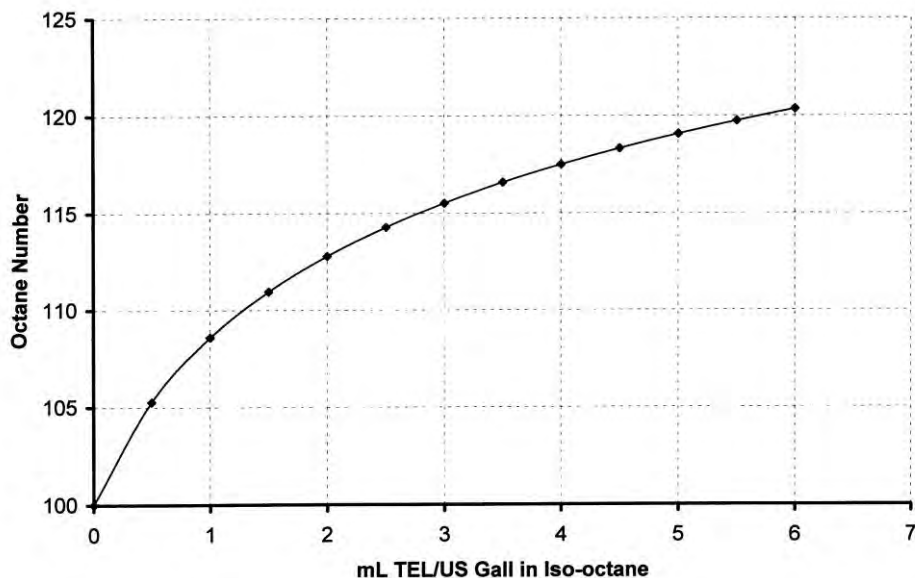

Figure 7. Octane Numbers above 100.

Assessment of the CFR Apparatus and Method

In drawing up the ‘tentative recommended practice’ given above, the Sub-Committee were well aware that it had not been available long enough to permit comprehensive experimentation to be carried out and it was therefore to be expected that some revisions in the method would need to be made as more experience was obtained. A survey was carried out, by a number of laboratories, of some 312 commercial gasolines followed by a statistical analysis of the results, which indicated that the test was capable of giving dependable results marked by a fair degree of accuracy and reasonable agreement between laboratories.

The test procedure was distributed to a wider audience including other countries. In Britain the Standardization Committee of the Institute of Petroleum Technologists became involved in exchanges of information and some tests were carried out, although not using the CFR engine which was not yet available in Britain. The British tests, carried out in three different engines, tended to show that iso-octane gave a greater degree of fluctuation in knock intensity as against benzene.²⁸ In both 1930 and 1931 representatives from the British Institute of

Petroleum Technologists presented papers at the annual SAE meetings in an attempt to persuade the CFR Committee away from using iso-octane as the high antiknock reference fuel.²⁹ The Anglo Persian Company (BP) carried out some road tests and noted that the road knock was not always strictly predicted by the laboratory tests. In particular the road tests graded fuel blends containing benzole and alcohol better than the laboratory ratings. The situation was summed up, by one of the British participants, as follows:-

1929 saw the general introduction of n-heptane and iso-octane as standard reference fuels from which blends could be prepared embracing the whole range of octane numbers then of practical significance. We were not in complete agreement with the USA regarding the selection of iso-octane because the reference blends were entirely paraffinic in character. These did not behave in a similar way to the average motor fuel, particularly in relation to their sensitivity to changes of engine condition. Our own suggestion was that crytallisable benzene should be the antiknock standard, but this was objected to because of its tendency to preignite in high duty engines and also because of its apparent extreme temperature sensitivity. Our objections to iso-octane were slowly overruled, and during the next two years we conformed fully to American opinion and henceforward calibrated all secondary reference fuels in terms of the new primary standards.³⁰

Once again it would seem that the American aversion to aromatics was exerting an influence.

At a cost of \$25 per US gallon both heptane and iso-octane were too expensive to use for large scale routine testing (gasoline at that time was around 17 cents per gallon wholesale) so it was decided to introduce a range of secondary reference fuels. Large quantities of, usually straight run, gasoline were manufactured and calibrated against the primary heptane/octane blends and then these secondary reference fuels were used for routine gasoline antiknock testing. Because the secondary reference fuels were generally straight run gasolines they were predominately paraffinic in nature.

At its meeting on 14 September 1931 the Cooperative Fuels Research Committee approved the knock testing equipment, octane number scale and tentative procedure, for general use by the automotive and oil industries.³¹

The 1932 Uniontown Tests

Whilst the new CFR Octane Number Test ranked fuels in a consistent and repeatable manner in the CFR engine, it became increasingly obvious that the test did not simulate service conditions as judged by both the motor industry and the discerning motorist. The committee acknowledged that the user of the fuel was the ultimate arbiter and the degree of knock experienced by him on the road was the commercially important criterion, so they agreed a three-point action plan. First

they would develop a road test procedure to rate fuels under service conditions; using this procedure they would then rate a series of fuels in a large variety of vehicles and compare the results with the CFR laboratory test results and, if significant differences occurred, they would then modify the laboratory test conditions and procedure to give rankings which matched those of the road tests.

At a meeting in January 1932 a special Road Test Correlating Subcommittee was formed and assigned the task of carrying out a series of cooperative road tests which were to be compared with the conventional CFR ratings. As finally constituted this subcommittee included in its membership representatives of fourteen automotive and petroleum laboratories.³² The subcommittee decided that further progress could be made only by engaging in an intensive cooperative effort at some central point, and the point chosen was on the National Turnpike near Uniontown, Pennsylvania. Here a hill, with a gradient for some 2½ miles, was deemed suitable for vehicles to be assessed for knock under loaded conditions.

A large group of some twenty three representatives and experienced operators gathered at Uniontown on 3 August 1932 together with seventeen test cars and supplies of fifteen test fuels. The operators were divided into teams and, using audible knock detection, a road test procedure was developed, termed the "Maximum Knock Method" (but since renamed the Uniontown Method). It was intended that, using this test method knock ratings would be carried out whilst accelerating up the Uniontown Hill, each fuel would be rated against secondary reference fuels, in each car, by at least two groups of three operators. Although the road ratings employed fifteen technical men working intensively for a period of three weeks, during which time more than 2,500 test runs were made, and approximately 10,000 observations of knock intensity representing 2,000 knock ratings, were recorded, however, not all of the fuels were rated in all of the cars by all technicians.

Not surprisingly, analysis of the results revealed that the vehicles varied considerably in the octane number of the reference fuel required to give knock-free operation, the highest vehicle requiring 83 and the lowest 60 with a mean around 71; this makes an interesting comparison with the Bureau of Mines survey of pump gasoline samples collected during August 1931 which reported an average of 60.8 for non-premium and 75.6 for premium gasolines.³³ Eleven of the fifteen fuels rated were representative of commercial gasolines (designated 'UT' series) and the remaining four were special 'cracked' fuels (designated 'RT' series). Analysis of results indicated that in all cases road ratings were below the CFR engine ratings by 0 to 10 octane numbers (mean 4.0) when considering all fuels and by 0 to 6 (mean 3.3) when considering only the commercial blends (Figure 8); however the picture is confused because not all of the fuels were rated in all of the cars.

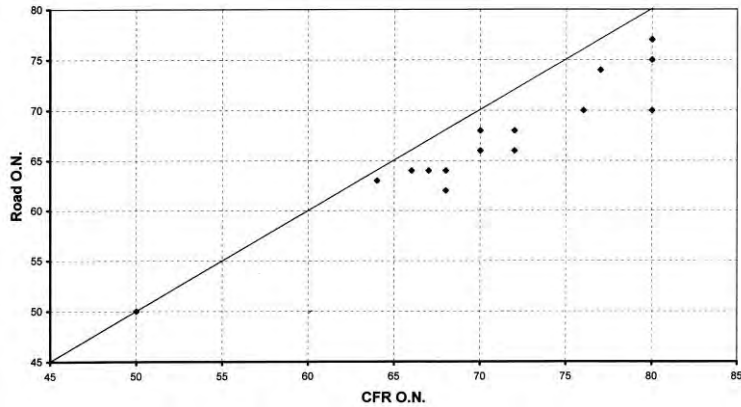

Figure 8. 1932 Correlation between Road and Laboratory Octane Numbers.

A.) Engine modifications. (Figure 9)

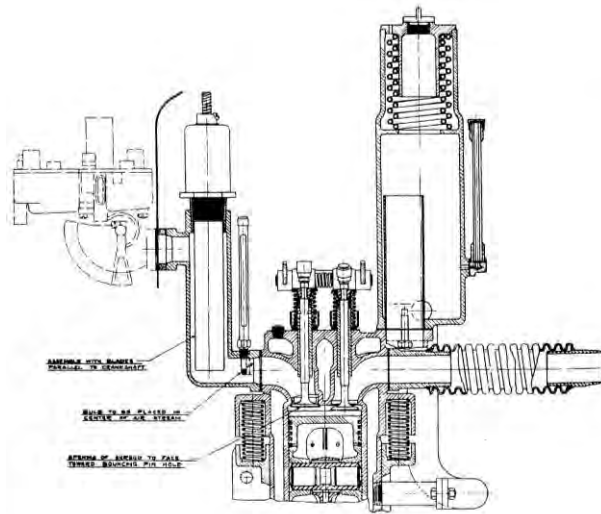

Figure 9. CFR Engine Modifications.

As a result of the road octane numbers down-rating the CFR octane numbers, it was decided to revisit the CFR engine test procedure and see if the test could be modified to bring the engine results into line with the road results. Since the cooperative approach had proved to be successful in the road testing the same approach was adopted for the CFR engine modification tests, hence eighteen representatives gathered at the Waukesha laboratories where seven engines were put at their disposal and over a period of two and one half weeks the same fuels rated in the road tests were assessed using 68 variations of CFR engine/procedure involving some 650 individual knock ratings.

The Piston Engine Revolution

The changes to the engine/procedure resulting from the work at Waukesha were as follows:-

The substitution of:

- (1) A shrouded intake valve.
- (2) An improved type of vapour condenser.
- (3) The introduction of a special electric heating unit between the carburettor and the intake port.

B.) Modifications to the Procedure.

- (1) An increase in engine speed from 600 rpm. to 900 rpm.
- (2) Variable spark timing
- (3) Mixture temperature set by the new heater unit to 300 ° F.

These changes gave a more reasonable correlation with the road ratings as shown in Figure 10.

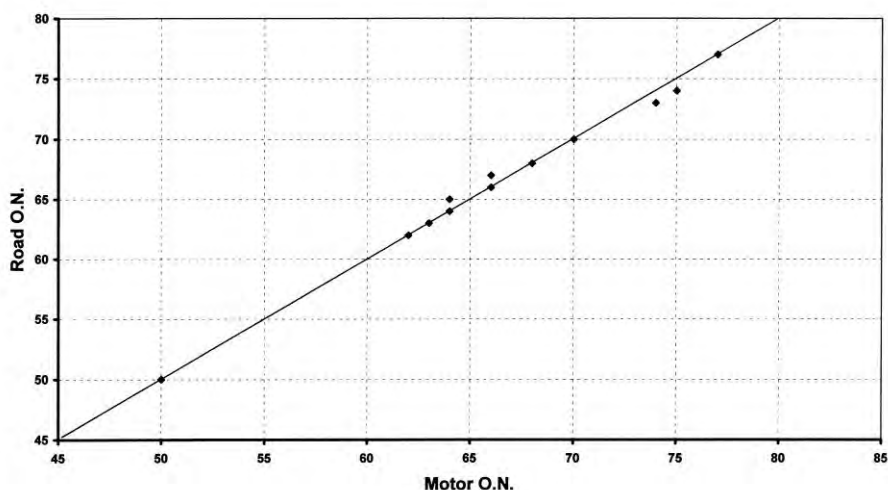

Figure 10. 1932 Correlation between Road and Laboratory Octane Numbers following Modifications to the Laboratory Engine and Test Procedure.

This new procedure, which was designated 'CFR Motor Method', was officially approved by the Cooperative Fuel Research Committee on 12 September 1932. At the same time the previous method was given the designation 'CFR Research Method'.

As more laboratories acquired CFR engines, inter-laboratory correlation checks were instituted and on 7 March 1933 the American Society for Testing

Materials adopted the CFR Motor Method as a 'Tentative Method of Test for Knock Characteristics of Motor Fuels'.³⁴

The 1934 Uniontown Tests

Not everyone was happy with the new procedure; it was particularly criticized for the narrow range of vehicles and fuels tested in the road programme. All the vehicles had large engines, and the fuels were mainly American commercial fuels. The British felt that the new intake system temperature of 300°F was unrealistically high and would have a significant effect upon the rating of fuels containing benzole, none of which had been included in the fuels tested.

The CFR Committee recognized the possibility that the Motor Method would require revision from time to time as improvements in engine design and fuel characteristics outmoded its provisions and, in late 1933 - early 1934, a programme was formulated to:

- 1) Check the validity of correlation between road and laboratory, knock-ratings.
- 2) Indicate promising paths of research directed toward better mutual adaptation of fuels and engines.

This time, participants were to include any organization in the United States willing to share both the work and expense involved in providing cars, equipment and supplies, together with representatives of foreign countries. Accordingly, invitations were extended to the companies in the oil, automotive, motor truck, engine and allied industries in the USA, and to the Office Nationale des Combustibles Liquides, of France, the Institution of Petroleum Technologists of Great Britain, and to the National Research Council of Canada.³⁵

Once again Uniontown Hill was chosen as the venue for the tests. Twenty five organizations and forty four individuals participated in the 1934 detonation road tests, almost twice the number in the 1932 project. The test fuels consisted of eight commercial fuels and nine non-branded fuels chosen to represent different types of refinery product. At the request of the British Institution of Petroleum Technologists a special blend containing 25% benzole was also included. Twenty four test cars were selected; all were of American manufacture, the selection being based principally on sales volumes. Hence, three identical low priced cars (Chevrolet, Ford and Plymouth) were included in greater numbers and a single Graham car was included because it was deemed to be indicative of possible future developments in high compression ratios (6.72:1) and supercharging. Four of the cars were marketed with optional cylinder heads so versions of each were tested. All combustion chambers were of side-valve layout but head materials varied between cast iron and aluminium, all vehicles were adjusted to factory settings.

After a month of testing for ten hours a day, covering a total of 50,000 miles, the results were analysed. The correlation between Road and Motor Method laboratory Ratings is shown in Figure 11. The maximum variation from the Motor

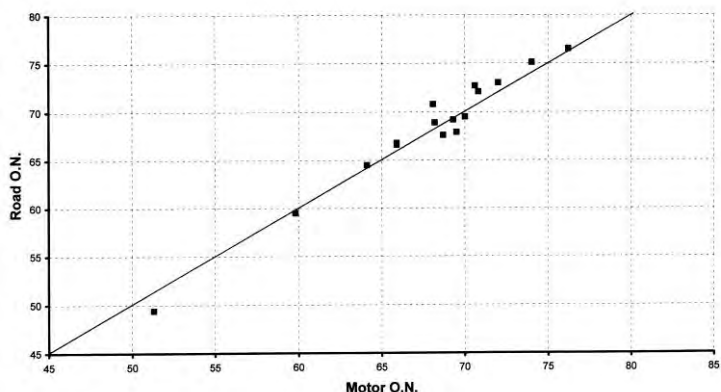

Figure 11. 1934 Correlation between Road and Laboratory Octane Numbers.

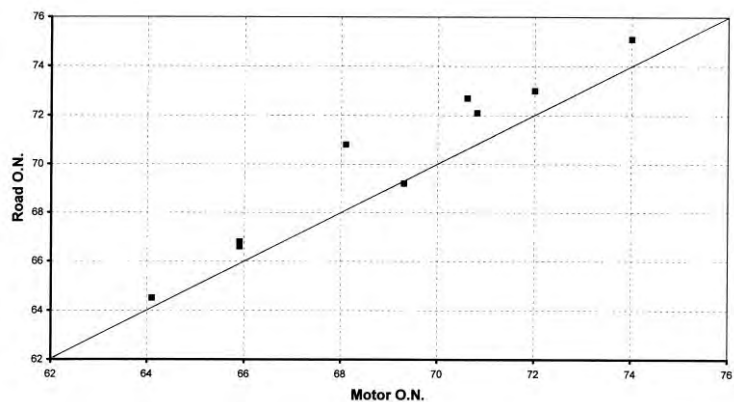

Figure 12. 1934 Correlation between Road and Laboratory Octane Numbers for non-Paraffinic Fuels

Method result occurred with the benzole blend and was +2.7 octane numbers, whilst the algebraic average of all fuels was +0.36. The conclusion reached was that whilst correlation was within the limits of experimental error of the technique involved, it was obvious that the precision and repeatability of both the road and laboratory ratings were not as good as might be desired.

Figure 12 is an interesting re-plotting of the correlation for those fuels known to contain significant quantities of non-paraffinic hydrocarbon components showing that, in the majority of cases, the road octane numbers are down-rated by the Motor Method test. This adds credence to the argument that one of the reference fuels should have been a non-paraffinic hydrocarbon.

Again, not everyone was in agreement and a member of the British Institute of Petroleum Technologists team commented:-

The method of (road) rating led to heated argument.....A more satisfactory interpretation of the 1934 results was difficult not only because of our limited knowledge of the subject, but also because commercial considerations frequently introduced an entirely non-scientific bias into the various discussions at which policy was decided, and it was not until the end of the decade that an improved technique was developed for road knock testing.³⁶

Because the benzole blend was not rated high enough in the laboratory engine to agree with the mean road figures it was agreed that the British Institute of Petroleum Technologists might, if it wished, make a correction to benzole blends to allow for this.

In later years another rating test procedure was developed (The Modified Borderline Test) in an attempt to overcome the shortcomings of the Uniontown procedure. However, no single test has yet been developed which will accurately predict the road anti-knock performance of a commercial gasoline in all vehicles, mainly because all vehicle engines are different and are affected to a greater or lesser degree by atmospheric conditions and driving style. Hence engine manufacturers and oil companies go to great lengths to ensure that vehicle engines are knock-free on all fuels manufactured to National Specifications which usually include a minimum requirement for both Research Octane Number (RON) and Motor Octane Number (MON).

Aviation Gasoline Anti-knock Testing Post 1930

By 1930 aviation development work in the USA was concentrated on the high performance, air-cooled engine that needed better cooling and higher anti-knock fuels to improve its high altitude performance. The bias towards insensitive paraffinic fuels containing lead anti-knock, reinforced by civil preoccupation with lean mixture performance under cruise conditions, was in contrast to British fuel philosophy based more on water cooling, traditional use of aromatic fuels and concern for maximum power. British workers had already recognized the value of aromatics for rich mixture performance at take-off.

The prestige of Schneider Trophy racing between America, Britain and Italy had led to high performance engines being built and special fuels prepared to meet their requirements. However, these fuels were not practical military or commercial propositions and they contributed little to the overall development of better fuels except to help demonstrate the vast improvement in engine performance which could be obtained from higher quality fuel. The American Curtiss water-cooled engines (D-12, V-1400 and V-1570) performed well in racing but were never supercharged or raised above 7:1 compression ratio; their fuel requirements were amply satisfied by Domestic Aviation Grade gasoline plus about 20% benzole and no special fuel was necessary. The 10:1 compression ratio Lion engine used by Britain in the 1927 race used a special leaded gasoline, whilst

British successes in the 1929 and 1931 races were obtained with the Rolls-Royce R engine for which special fuels were evolved by F.R. Banks of the Ethyl Corporation; these are shown in Table 4 below and were probably fully equal in performance to the 100/130 grade fuel of WWII.³⁷

Table 4. British Schneider Trophy Fuels.

Blend %	1929 Contest Fuel	1931 Contest Fuel	1931 Speed Version Fuel
High Duty Avgas	22	20	-
Benzole	78	70	30
Methanol	-	10	60
Acetone	-	-	10
TEL ml/Gal	4	4	5
Remarks	Run rich in order to keep engine cool.	Gave violent preignition when run in a high temperature liquid cooled engine later*.	Gave 2590 hp at 3400 rpm and world record speed of 407.5 mph.

*This illustrates the critical temperature sensitivity of alcohol blends.

The US Army Air Force introduced leaded 87 ON gasoline in 1930; many problems arose in both engines and aircraft when it went into service in 1931, resulting in some squadrons obtaining permission to revert to DAG fuel. Eventually, by painstaking development work the problems were ironed out and service opposition was overcome.

In 1932/33 the CFR Committee formed an Aviation Fuels Division (CFR-AFD) to investigate combinations of all types of fuel and engines and this committee played a valuable part in progressing the adoption of higher quality fuel.

In 1932, leaded 87 ON aviation gasoline was introduced into Britain for engine development work and came into full service availability in 1934. The standard DTD 134 specification for unleaded fuel (ca 75 ON) was superseded in 1933 by DTD 224 (77 ON unleaded) for all existing engines unable to take advantage of lead and by DTD 230 (87 ON with 3.5 ml TEL/UKgal) for all new types of RAF engine. The critical requirements of these specifications are given below in Table 5.

Table 5. 1933 Brief British Aviation Gasoline Specifications.

Test	DTD 224	DTD 230
Specific Gravity max	0.79	0.79
<u>Distillation</u>		
Per cent volume to 75°C min	10	10
“ “ “ “ 100°C min	50	50
“ “ “ “ 150°C min	90	90
Final Boiling Point °C max	180	180
Reid Vapour Pressure lb max	7	7
Actual gum mg/100 ml max	10	10
Potential gum mg/100 ml max	10 + actual	10 + actual
Total sulphur % wt max	0.15	0.15
Freezing point °C max	- 50	-60
TEL content mL/UK gal max	Nil	3.5
Octane Number (Motor Method) min (260° F mixture temp)*	77	87

* Octane Numbers 2 lower if 300°F inlet temperature used.

The US Army engine test method was mild and gave ratings about 4 ON higher than above method i.e. US 100 ≈ 96 MM.

In 1932-33, the US Army (Wright Field) acquired small quantities of experimental 100 ON fuel and used it to demonstrate that 15-30 % more power was obtainable from it in Wasp and Cyclone engines than from 90 ON fuel. The fuel consisted of a leaded blend of isooctane and Californian gasoline that rated 100 ON in a CFR engine fitted with a special Wright Field cylinder. In 1935, Wright developed a special Cyclone engine of 8:1 compression ratio showing that a 15% fuel consumption advantage could be obtained from such a fuel. The US Army then issued Specification 2-92 Grade 100, and Specification 2-95 Grade 92, for 100 and 92 ON (Army Method) fuel with 3.6 ml TEL/UKgal. The Air Force standardized on this fuel in 1936. This was a bold and imaginative step on the part of the Army Air Force authorities in adopting 100 ON fuel before the engines requiring it were available in service. They thus provided industry with the commercial incentive to set up large scale production facilities and, by publishing the results of all their work, forced a somewhat conservative General Staff into acceptance of 100 ON fuel as standard for all combat aircraft.³⁸ The Navy was more cautious, adopting 91 ON fuel with 0.6 ml TEL/UKgal as standard instead.

The American authorities must be given the credit for backing the initial development of synthetic isoparaffins. Isooctane was first prepared by Edgar in 1927 by cold acid treatment of tertiary butyl alcohol to give di-isobutylene (DIB)

which was then hydrogenated to isooctane. Following the Army call for 100 ON fuel, the first quantity production was undertaken in 1934 by Shell and Standard Oil of New Jersey, using the cold acid process to produce DIB from isobutylene for subsequent hydrogenation to isooctane. Thereafter high-octane fuel production became subject to direct commercial competition with a large element of technical prestige also involved.

In 1937, the British Air Ministry issued a provisional specification (DTD 100 ON) for 100 ON fuel and urgent engine development work over the next two years resulted in its adoption as standard RAF service fuel in September 1939. About the same time the DTD 230 specification was revised to 90 ON at 4 ml TEL/UKgal, with the permissible lead level being progressively raised during the war years to 4.8 ml/UKgal (1941) and then to 5.5 ml/UKgal (1943).

During the 1930-40 period, America was not in the least interested in the rich mixture performance for the reasons outlined earlier; this attitude persisted until the attack on Pearl Harbour in December 1941 turned American aviation fuel philosophy onto a war basis. Although the British had a more direct interest in this aspect of fuel quality, there was no control of rich mixture performance in pre-war days, probably because the available fuel was sufficiently good for the engines of the period. With the advent of leaded fuels and supercharged engines however, an intensive study was made of rich mixture performance on military engines. The Rolls-Royce liquid-cooled Kestrel was shown to give a superior power performance on aromatic and highly leaded fuels relative to the Bristol Pegasus air-cooled engine. The provisional 100 ON specification issued in 1937 contained no rich mixture-rating clause but bench and flight-testing established the order of performance required; actual fuel supply contracts required purchases to have a rich mixture rating (RMR) at least equivalent to a reference batch of fuel. Since full scale testing is expensive the British Air Ministry developed a standard single cylinder RMR procedure based on a Bristol Pegasus 8:1 CR cylinder (most severe service engine) in which fuel batches were checked against an AM 100 reference fuel.

Thus at the beginning of the war, 100 ON fuel was specified for both American and British high performance engines but only America had a sufficient production capacity and Britain imported the necessary supplies from American Eastern sea-board sources. Synthetic isoparaffins were the major components, produced from olefinic gas streams by variations of the catalytic polymerisation/hydrogenation route used by Shell and Standard Oil New Jersey.

With American entry into the war at the end of 1941, increased effort was devoted to the development of a standard engine test procedure for rich mixture rating. (The British single cylinder Pegasus test had been replaced by a similar Hercules test, this latter engine now being the most severe in service.) The aviation fuel specifications still contained no rich mixture test clause. America had now come to realize the need for maximum power from military engines and the

importance of rich mixture rating and the role of aromatics. Their supplies varied a bit in quality between about 100/104 and 100/130 levels; at the low end of the range there was difficulty with high power operation of US engines at rich mixture and take-off power was limited to 90 per cent of normal.

Because the octane number scale is non linear with respect to engine performance a new test method and system was developed. By measuring the knock-limited power of a wide variety of supercharged aviation-type engines on iso-octane and then measuring their percentage gain in power when various amounts of TEL were added, it was subsequently possible to replicate these tests using a special supercharged version of the CFR engine and express the results in terms of Performance Number (PN). Therefore, a fuel of say, 120 PN, will allow a supercharged engine to develop 20 per cent more knock free power than with a fuel of equivalent anti-knock performance to clear iso-octane (100 ON/PN) under the same conditions. Although this new test (designated the “Supercharge Method”) was based on the CFR engine, so many modifications were made to both the hardware and testing method that, the resulting Performance Numbers cannot be compared with Octane numbers above 100 ON nor can they be used as an indicator of the relative power producing ability of gasoline in unsupercharged engines. The relationship between PN and Iso-octane plus TEL is shown in Figure 13.

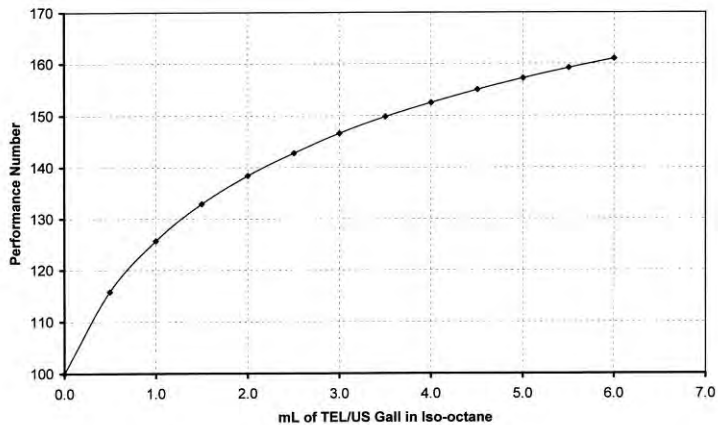

Figure 13. Relationship between Performance Numbers and Iso-octane plus TEL.

As the war effort increased and supplies of high octane blending components reached adequate levels, the need for an even higher performance production fuel resulted in 115/145 Grade being called for in late 1944 by US specification AN-F-33; the equivalent British specification DED 2476 followed in 1946. Some development work was undertaken on even higher performance fuels; however, these proposed fuels never materialized because the aviation gas turbine

was already demonstrating power outputs that made further development of the aviation piston engine futile.

Acknowledgement

The author would like to acknowledge the assistance given in the preparation of this paper, by many former colleagues and friends in the international oil industry. He has drawn deeply on their knowledge, work, experience and writings; in particular, he has quoted freely from the writings of the late Mr. D. T. McAllan (see reference 7 below).

References

1. E.G. Hancock, *Technology of Gasoline, Critical Reports on Applied Chemistry* Volume 10 (Blackwell Scientific Publications, Oxford, 1985), pp. 2-3.
2. E.G.D. Liveing, *Pioneers of Petrol; a centenary history of Carless, Capel and Leonard, 1859-1959.* (H F & G Witherby, London, 1959), pp. 4-5.
3. *Ibid.*, p. 43.
4. H.R. Ricardo, *The Progress of the Internal Combustion Engine and its Fuel*, (Melchett Lecture given to The Institute of Fuel, 9 October 1935), p. 3.
5. *Ibid.*, p. 4.
6. Liveing, p. 56.
7. D.T. McAllan, "The Development of Aviation Piston Engines and their Fuels", *British Petroleum Research Centre, Technical Memorandum No 110 181, (Non-Confidential)* (20 September 1968). NB. In the British Library On-line Catalogue the author's name is incorrectly spelt as D.T. McAllen.
8. Hancock, p. 9.
9. H.R. Ricardo, 'The Influence of Various Fuels on the Performance of Internal Combustion Engines' *Automobile Engineer* 11 (1921), pp. 51, 92, 130, 169, 201, 242, 279.
10. E.L. Marshall & K. Owen, Eds., *Motor Gasoline* (The Royal Society of Chemistry, 1995), p. 4.
11. C.F. Kettering, *Oil and Gas Journal* 18 (1919), p. 62.
12. G.A. Green, 'The Employment of Less Volatile Fuels for Motorcoach Engines', *SAE Journal* 25 (1927), p. 604.
13. C.F. Kettering, 'Combustion of Fuels in Internal Combustion Engines', *SAE Transactions* 15, Part 2 (1920), p. 454.
14. Green, p. 606.
15. R. Schlaifer & S.D. Heron, *Development of Aircraft Engines and Fuels* (Graduate School of Business Administration, Harvard University, 1950)
16. McAllan.
17. H.K. Cummings, 'Methods of Measuring the Antiknock Value of Fuels', *SAE Transactions* 22, Part 1 (1927).
18. T.A. Boyd, 'Standard Engine for Fuel Tests' *SAE Journal* 24 (February 1929), p. 212.
19. T.A. Boyd, 'The Cooperative Research Apparatus and Method for Knock Testing. A Report of Progress in the Work of the Detonation Sub-committee', *API* 12 (1931), p. 52.
20. Midgley T & Boyd T A., "Methods of Measuring Detonation in Engines" *SAE Transactions Vol 17, Part 1*, (1922) p. 126.
21. Midgley, p. 131.
22. T.A. Boyd, "The Cooperative Research Apparatus and Method for Knock Testing. A Report of Progress in the Work of the Detonation Sub-committee." *API, Vol 12*, (1931) p. 56.
23. Anon., "Summary of Knock Test methods. Report of Subcommittee on Methods of Rating Fuels for Knock Tendency" *SAE Journal, Vol 25*, (July 1929) p. 80.
24. G. Edgar, "Measurement of Knock Characteristics of Gasolines in Terms of a Standard Fuel" *Industrial and Engineering Chemistry, Vol. 19* (1927) p. 145.
25. J.M. Campbell, W.G. Lovell, T.A. Boyd, 'Detonation Characteristics of Some of the Fuels Suggested as Standards of Antiknock Quality', *SAE Transactions* 25 (1930), p. 128
26. G. Edgar, 'Detonation Specifications for

The Piston Engine Revolution

Automotive Fuels', *SAE Transactions* 22, Part 1 (1927), p. 55.

27. Campbell, p. 126.

28. Anon., 'Knock Rating of Motor Fuels. Note on Experiments Carried out in 1930', *Journal of the Institute of Petroleum Technologists* 17 (May 1931), p. 69.

29. C.H. Barton, C.H. Sprake, R. Stansfield, 'Comparison of Antiknock Ratings Determined in Different Laboratories', *SAE Transactions* 25 (1930), p. 132; C.H. Barton, C.H. Sprake, R. Stansfield & O. Thornycroft, 'Knock Rating of Motor Fuels' *SAE Transactions* 26 (1931), p. 444.

30. R. Stansfield, private undated communication.

31. T.A. Boyd, 'The Cooperative Fuel Research Apparatus and Method for Knock Testing', *Proceedings of the American Petroleum*

Institute 12, section 3 (1931), p. 46.

32. C.B. Veal, W.H. Best, J.M. Campbell & W.M. Holaday, 'Antiknock Research Coordinates Laboratory and Roar Tests', *SAE Transactions* 28 (March 1933), p. 105.

33. *Ibid.*, p. 114.

34. C.B. Veal, 'CFR Committee Report on 1934 Detonation Road Tests', *SAE Transactions* 30 (May 1935), p. 165.

35. Veal, 'CFR Committee Report', pp. 165-179.

36. Stansfield.

37. F.R. Banks, 'Some Problems of Modern High-Duty Aero Engines and their Fuels' *Journal of the Institute of Petroleum Technologists* 23 (Feb. 1937), p. 108.

38. Lieut F.D. Klein, 'Future Possibilities of 100-Octane Aircraft-Engine Fuel', *SAE Journal (Trans)* 39, No. 2 (1936), p. 304.

Notes on Contributor

Ed Marshall served an Indentured Apprenticeship in Agricultural Engineering and, following service in the Royal Air Force, he joined British Petroleum Research carrying out studies into the relationship between engines and their fuels. In 1978 he was elected to a Fellowship at Cambridge University where he spent a number of years investigating combustion in 'lean burn' engines. He returned to BP to set up and run a facility carrying out fundamental combustion studies in reciprocating engines, using Laser Doppler Anemometry. Upon retirement from BP he ran his own consultancy for 10 years. He has published a number papers and technical articles and is the editor of a book on motor gasoline published by The Royal Society of Chemistry. He is a member of the Newcomen Society Activities Sub-Committee and has arranged numerous visits including study weekends based on Humberside, Northern Ireland and St Helens.

Email: elm.tudor@btopenworld.com